



DC Microgrid | Steady State Analysis

Direct Current Technology and Systems

Schindler, J., Murillo, N. & Matta, Stephanie.

Presentation 1 – DCTS ETSEIB | April 1st 2025.



UNIVERSITAT POLITÈCNICA DE CATALUNYA
BARCELONATECH
Escola Tècnica Superior d'Enginyeria
Industrial de Barcelona



DC Microgrid | Steady State Analysis

Direct Current Technology and Systems



Nicolás Murillo

B.Sc. Electrical
Engineering

Erasmus+ DREAM program



Joel Schindler

B.Eng. Electrical
Engineering

Erasmus+ DREAM program

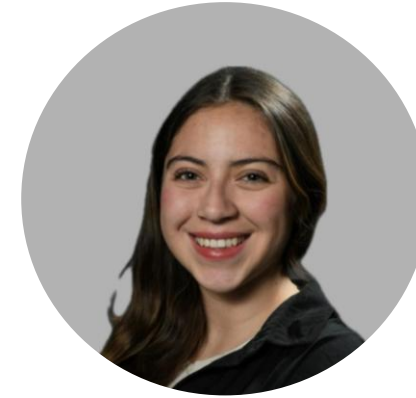

Stephanie Matta

B.Sc. Energy & Sustainable
Development Engineering

Erasmus+ DREAM program

Chosen Network for Studies: DC Microgrid

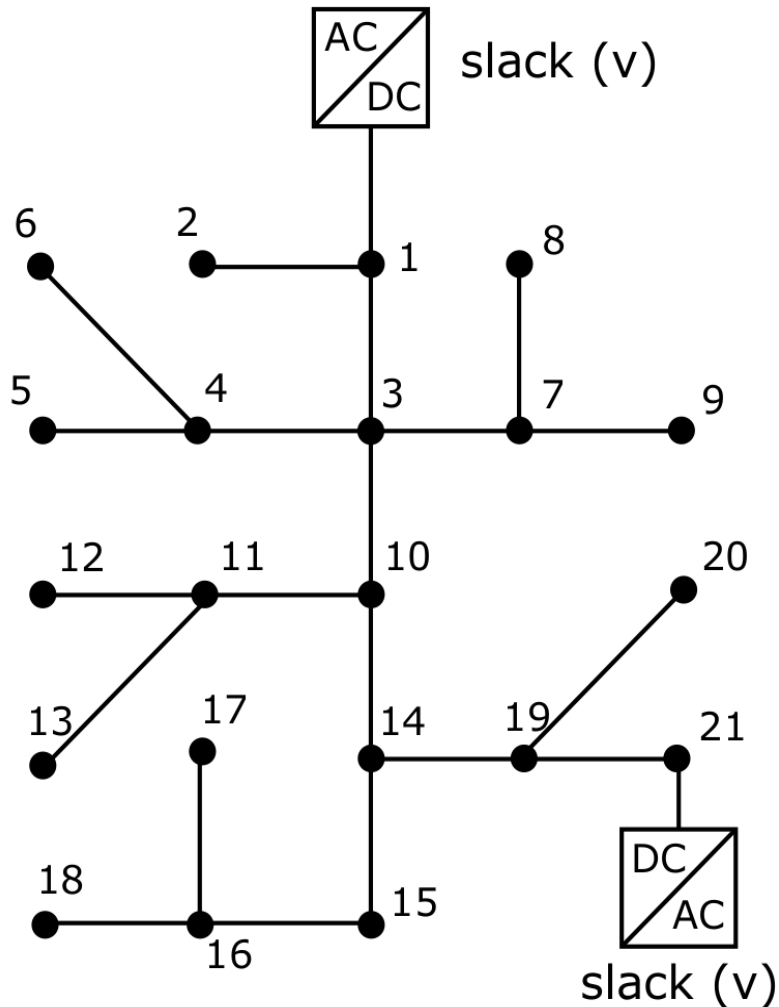

Literature Reference: Danilo, O., et. al. (2020). Numerical methods for power flow analysis in DC networks: State of the art, methods and challenges. *Electrical Power and Energy Systems*. <https://doi.org/10.1016/j.ijepes.2020.106299>.

Electrical parameters for the 21-node test system (all values are in p.u.).

Node i	Node j	R_{ij}	P_j	Node i	Node j	R_{ij}	P_j
1	2	0.0053	0.70	11	12	0.0079	0.68
1	3	0.0054	0.00	11	13	0.0078	0.10
3	4	0.0054	0.36	10	14	0.0083	0.00
4	5	0.0063	0.04	14	15	0.0065	0.22
4	6	0.0051	0.36	15	16	0.0064	0.23
3	7	0.0037	0.00	16	17	0.0074	0.43
7	8	0.0079	0.32	16	18	0.0081	0.34
7	9	0.0072	0.80	14	19	0.0078	0.09
3	10	0.0053	0.00	19	20	0.0084	0.21
10	11	0.0038	0.45	19	21	0.0082	-

Linear power flow vs. Minimization Algorithm

Linear Power Flow	Minimization Algorithm
$P_i^{\text{inj,DC}} = V_i^{\text{DC}} \sum_{j=1}^{N^{\text{DC}}} I_j = V_i^{\text{DC}} \sum_{j=1}^{N^{\text{DC}}} \frac{V_i^{\text{DC}} - V_j^{\text{DC}}}{R_{ij}} \quad \leftarrow \text{apply} \quad V_i^{\text{DC}} = 1 \text{ p.u.} + v_i^{\text{DC}}$ $P_i^{\text{inj,DC}} = \sum_{j=1}^{N^{\text{DC}}} \frac{v_i^{\text{DC}} - v_j^{\text{DC}}}{R_{ij}} \quad \xrightarrow{\text{Matrix Eq.}} \quad \mathbf{v}^{\text{DC}} = (\mathbf{G}^{\text{DC}})^{-1} \mathbf{P}^{\text{DC}}$	<pre> fsolve (initial_condition, function) out = function (variable, in) { Voltages: out() = - in_V() + variable_V () Power: out() = - in_P () + variable_V () * variable_i () Kirchoff: out() = - i + in_G () * variable_V () } </pre>

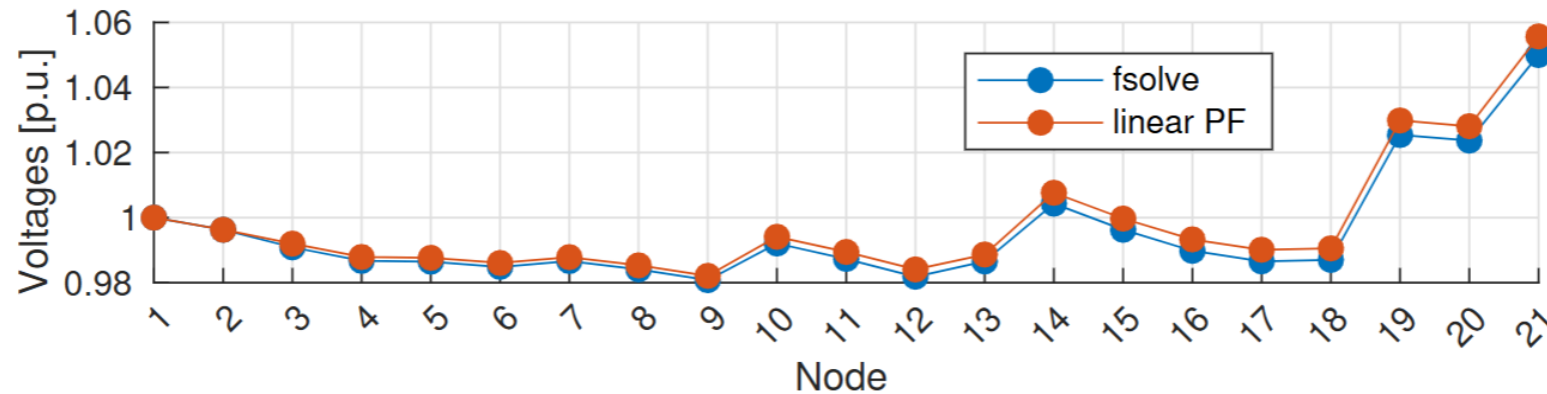

Industry Reference for Time Series

For ensuring accurate steady-state representation under realistic and regulation-aligned operating scenarios.
All profiles rescaled to preserve temporal behavior.

Industrial Loads: Derived from **5-minute SCADA** data of **two facilities**

- Plastics manufacturing (Type I)
- Frozen storage (Type II);



Residential Loads: Based on **standardized REE 2025 profiles**

- P2.0TD (general household Type I)
- P3.0TDVE (household with EV charging Type II);



Generation Profiles: Extracted from **SCADA measurements** of two utility-scale **PV plant**

- Malvas I (stable irradiance Type I)
- San Miguel (variable irradiance Type II).



DC Microgrid Components Distribution

Node	Load [kW]	Load type
8	70	Residential 1
9	36	
19	4	
20	36	
11	45	Residential 2
12	68	
13	10	
2	70	Industrial 1
4	36	
5	4	
6	36	
15	22	Industrial 2
16	23	
17	43	
18	34	

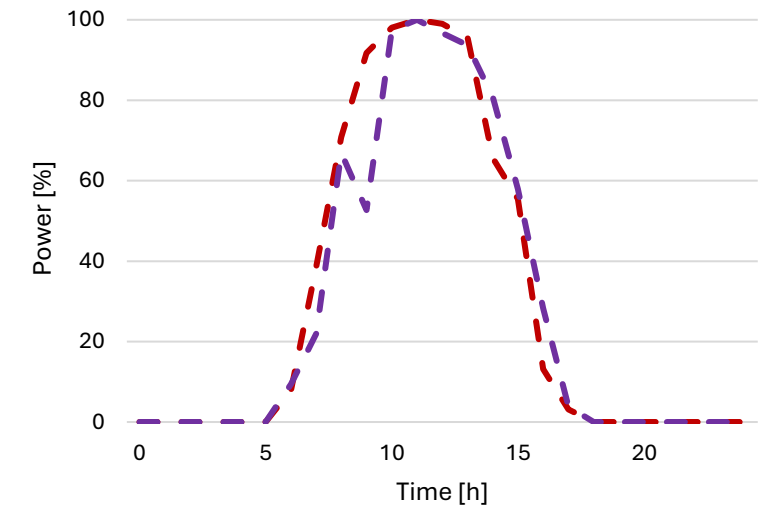
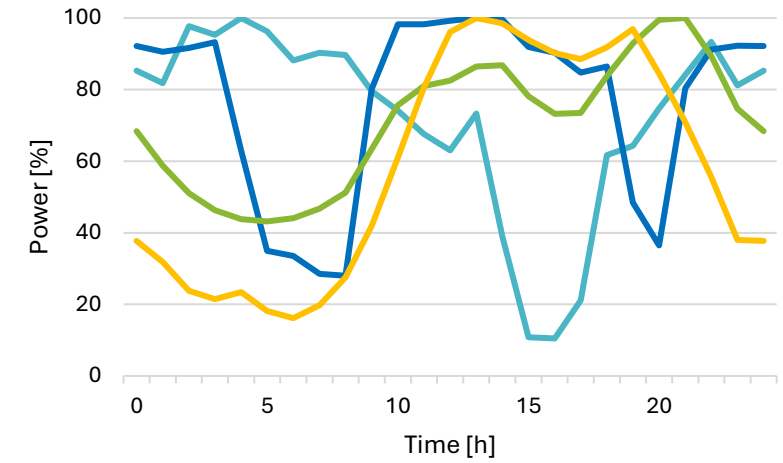
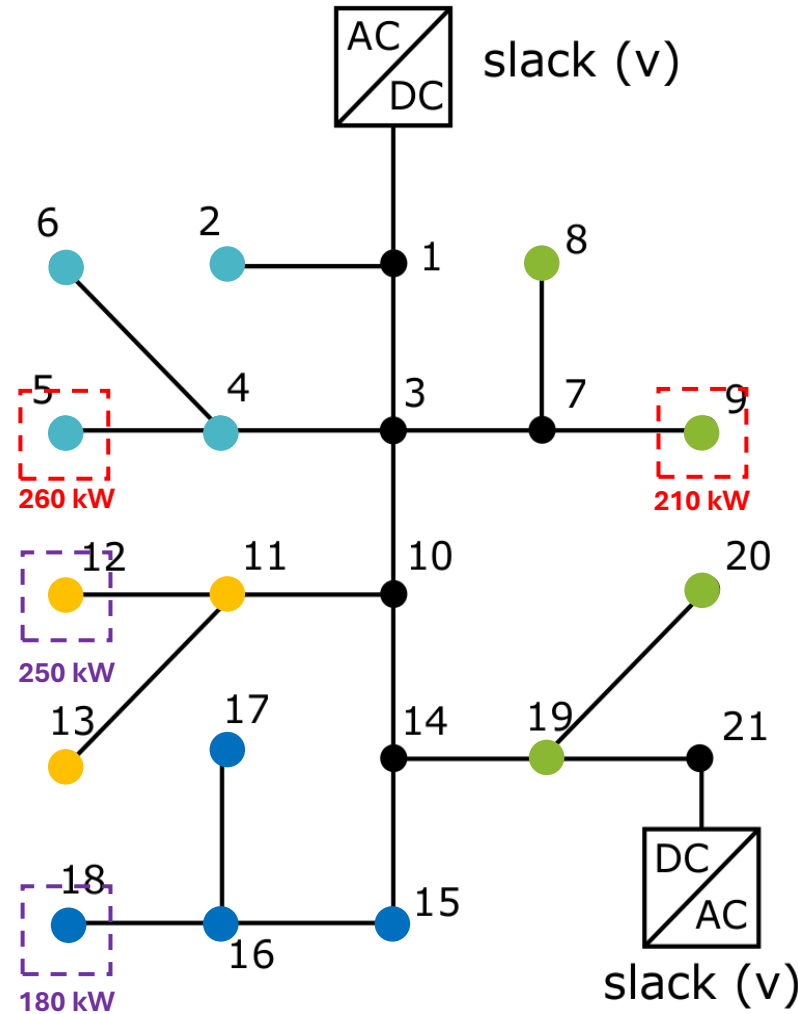

- Industrial Load Type 1
- Industrial Load Type 2
- Generation Profile Type 1
- Residential Load Type 1
- Residential Load Type 2
- Generation Profile Type 2

Power flow exchange

Scenario 1: Grid dual connection to main grid in bus 1 and 21.

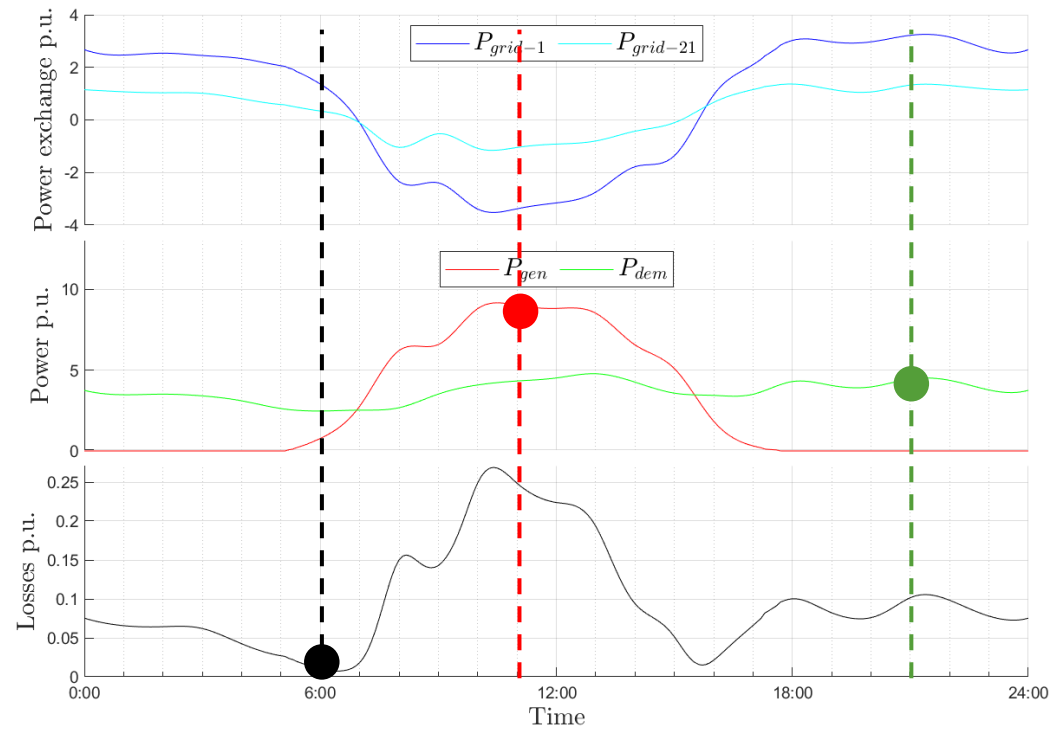

Scenario 2: Grid connection to main grid only in bus 1

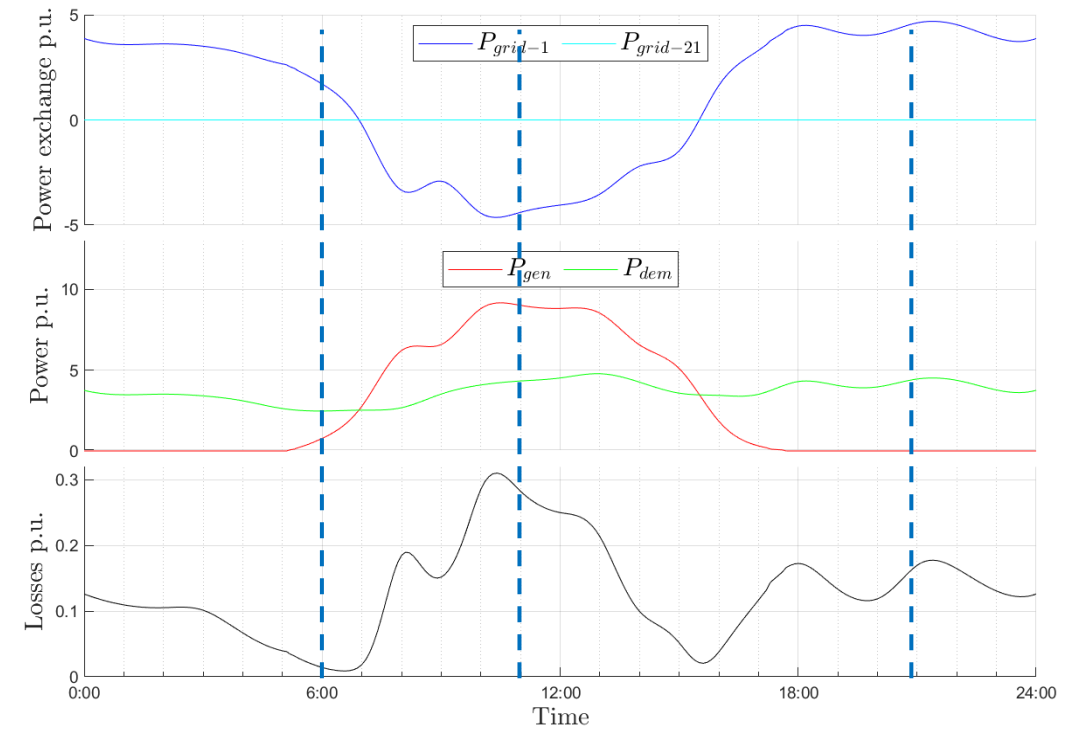

Scenario 1 (Grid connection to main grid in bus 1 and 21)

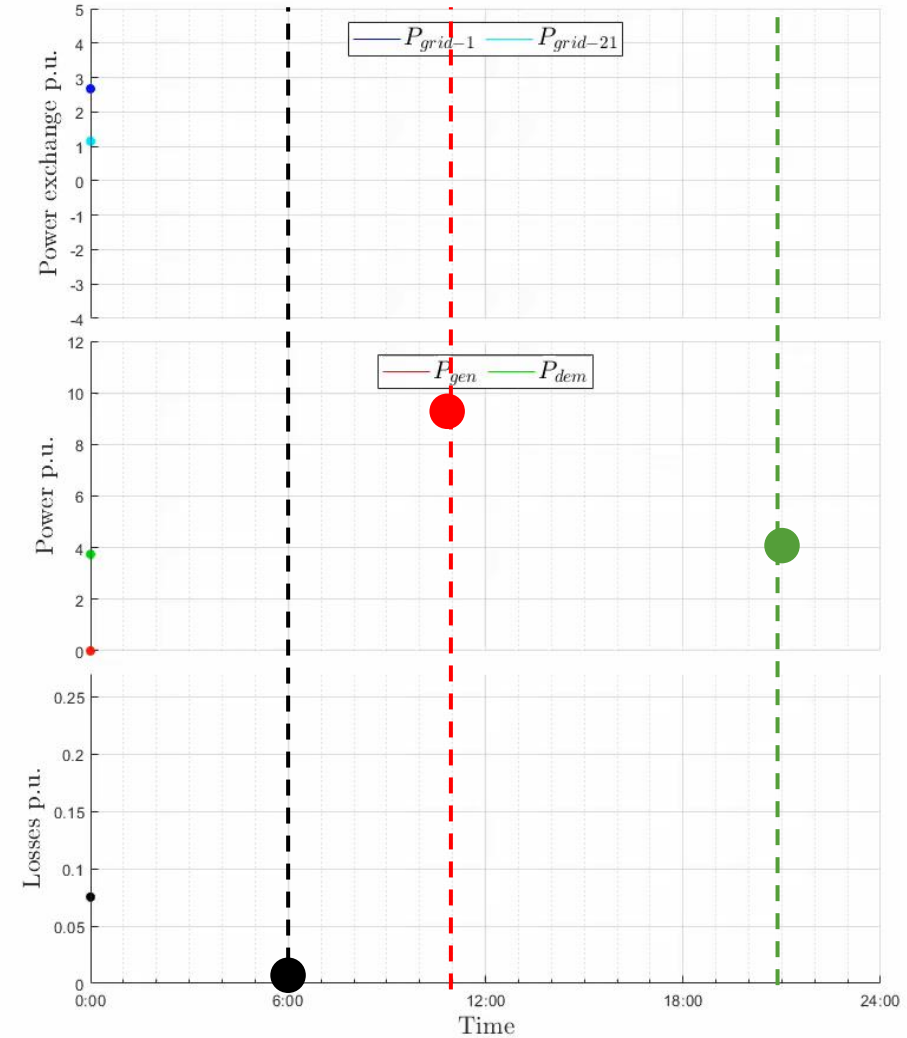
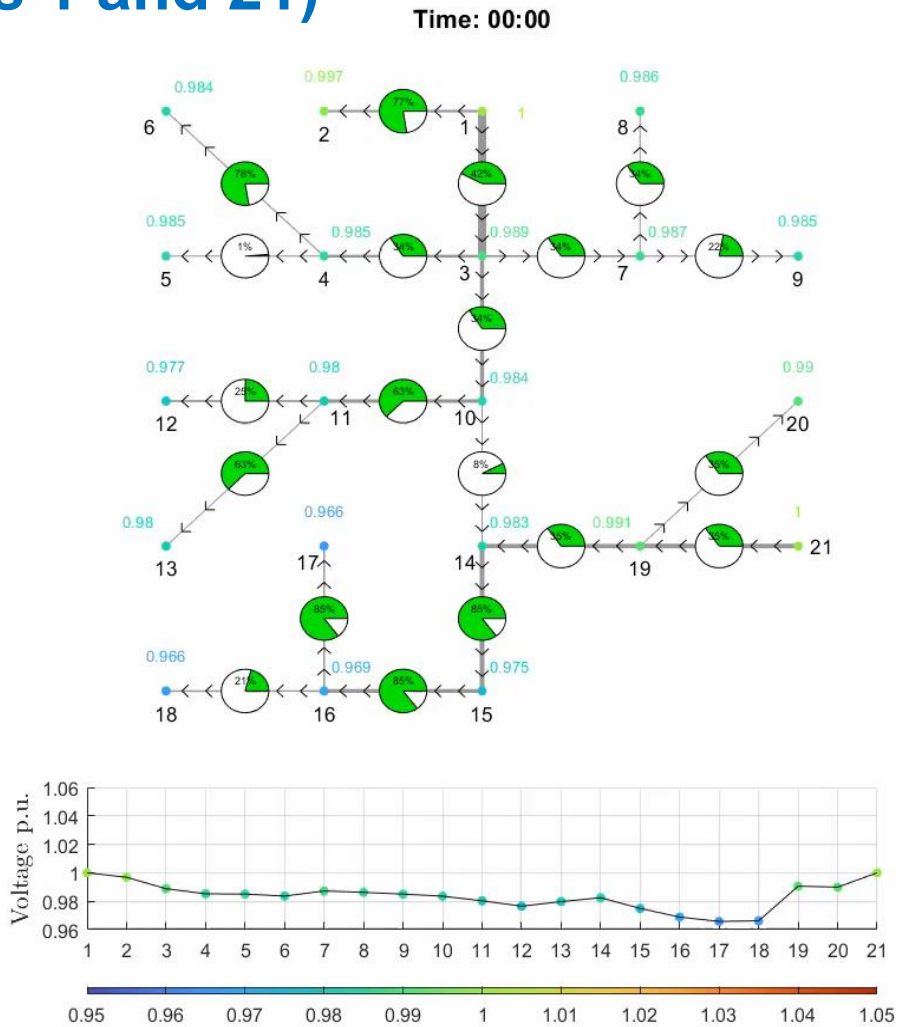

Scenario 2 (Grid connection to main grid only in bus 1)

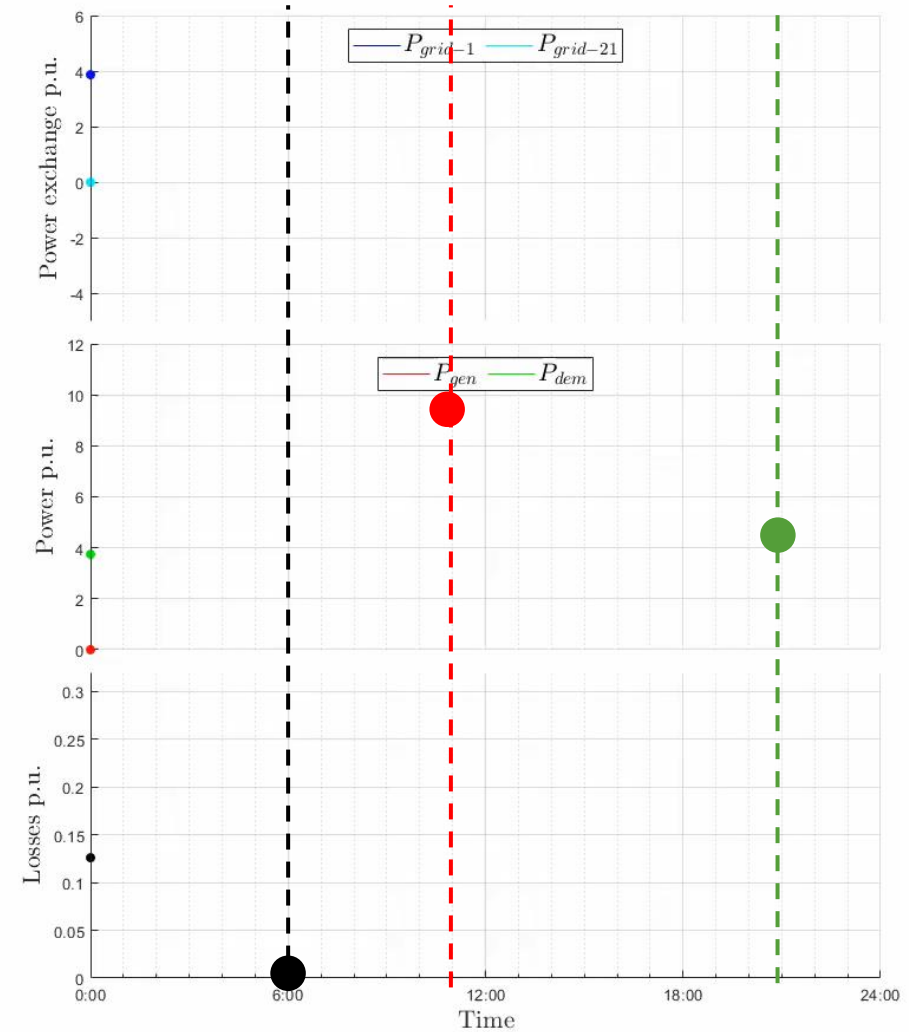
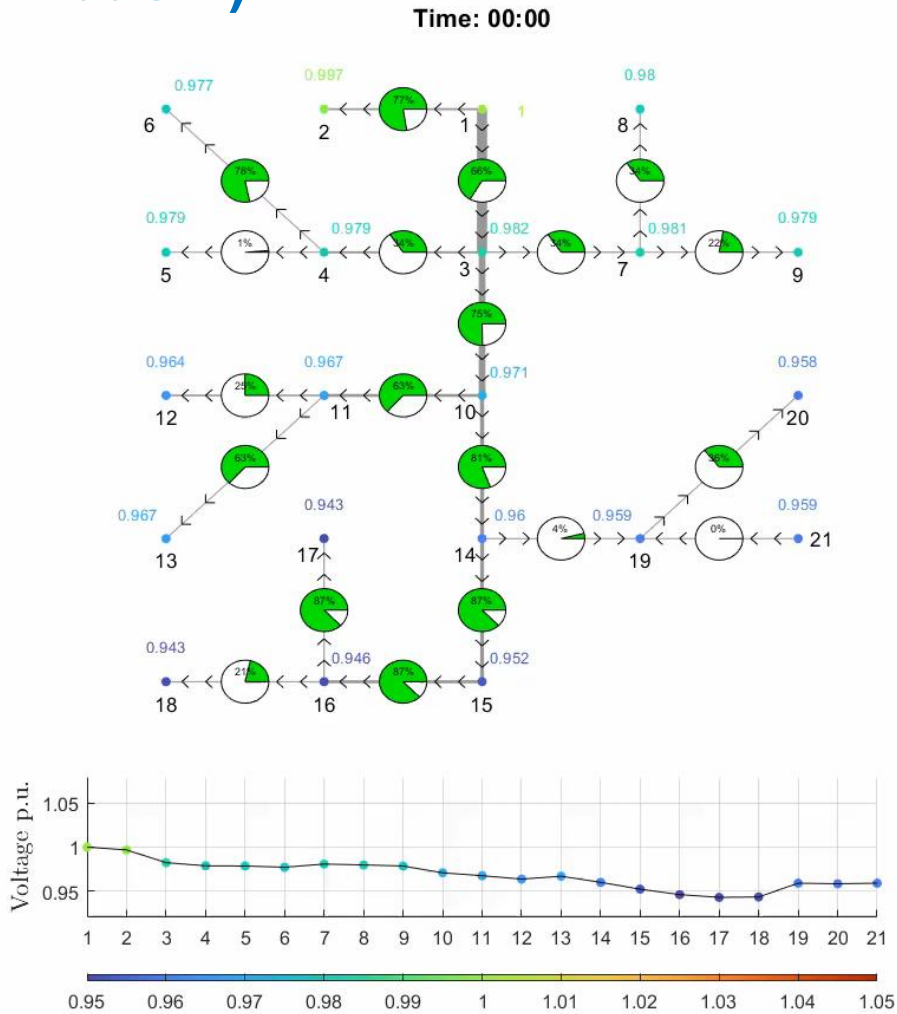

Scenarios comparison

Magnitude	Two connections Main Grid	One connection Main Grid
Purchased Power (N1)	3.6890 MWh	5.2701 MWh
Delivered Power (N1)	2.0693 MWh	2.6563 MWh
Purchased Power (N21)	1.5237 MWh	-
Delivered Power (N21)	609.7 kWh	-
Highest current	391.2 A	514.3 A
Lowest voltage	963.8 V	936.1 V
Highest voltage	1.047 kV	1.0628 kV
Power losses	234.1 kWh	312.8 kWh

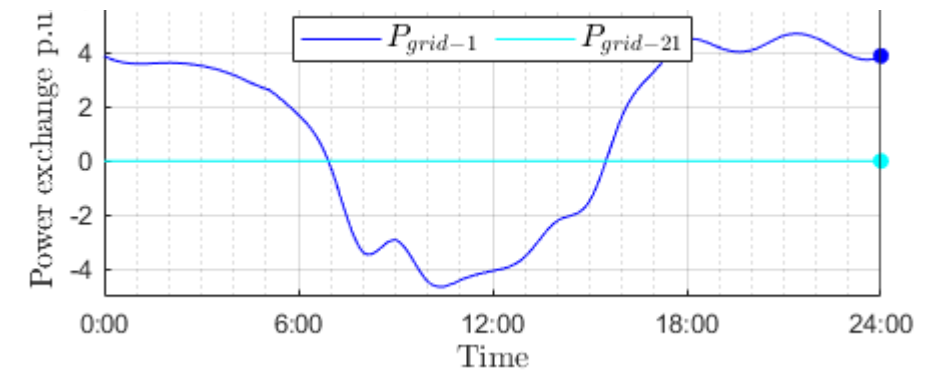
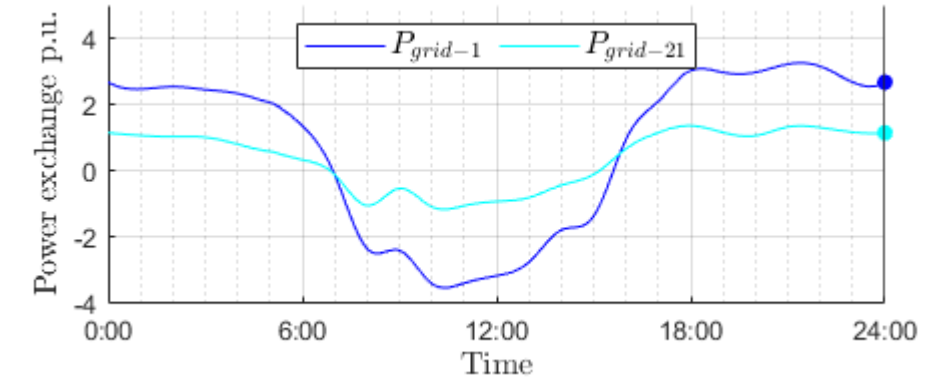

Connecting the microgrid to two main grid buses (N1 and N21) results in lower power losses (-25%), reduced maximum current (-24%), and improved voltage stability, compared to the single-connection case. The setup distributes power flow more efficiently and alleviates stress in heavily loaded branches, enhancing overall system resilience.

GridCal comparison

Both configurations show nearly identical numerical behavior. Voltage errors remain within the solver's tolerance ($\sim 10^{-6}$ p.u.), with minor differences at intermediate iterations. No relevant electrical deviations were observed.

